

KINEMATICS OF THE WORKING BODIES OF THE MECHANISM OF THE HINGE COUPLING AT DIFFERENT VALUES OF THE NUMBER OF INPUT LINK SPEEDS

Sherzod Gulmurotovich Hamroyev

Head teacher, Department of Mining Electromechanics, Navoi State Mining and Technology University
hamroyev.sherzod@mail.ru

ABSTRACT

The laws of motion of the working bodies, consisting of three output links at different numerical values of the revolutions of the input link, are experimentally determined, and an interpolation cubic spline function of the law of motion is found using the Mathcad program. The first of the three working bodies is the output half-coupling, which circulates the liquid. The first-order numerical derivative obtained from its law of motion, that is, the variability of the angular velocity of the output half-coupling in one period shows that it operates in a non-stationary mode. The second and third output working links, consisting of telescopic rods, transmit rotational motion from the input link of the mechanism to the output link of the coupling half through the reciprocating movement of its piston, and at the same time act as a piston pump, accelerating the process of mixing the liquid, sucking and pumping them.

Keywords: articulated clutch, structural diagram, mechanism model, input and output links, law of motion, regression, angular velocity, gear ratio.

INTRODUCTION

Stirring speeds up the processes associated with heat and mass transfer. Heat and mass transfer in liquid media is one of the most effective ways to intensify processes in various industries. Preparation of food products and medicines, various materials in the chemical and microbiological industry, carrying out numerous processes associated with water purification, obtaining modern non-metallic materials replacing steels and alloys, processing rocks in order to isolate precious materials, as well as obtaining various products in the defense industry. industry, requires the use of mixing processes.

The 15th European Mixing Conference “Mixing-15”, held in St. Petersburg in 2015, clearly showed how much experimental and computational research methods have changed over the past



20 years. Quantitative methods for visualizing the structure of flows in devices with stirrers, computational fluid dynamics have become a necessary tool for modern research. In 2018, V. M. Barabash, R. M. Abiev and N. N. Kulov reviewed and commented on 97 articles and monographs on the theory and practice of mixing. A large number of these works, which consider various methods of mixing (mechanical, pneumatic, jet, vibration, magnetic, etc.), it is noted that in more than 95% of cases, mechanical mixing is used in practice all over the world, assuming the presence in working volume of the rotating mixer apparatus.

Today, the mixing devices used in production do not always fully comply with the technological parameters required by industrial enterprises. The reasons for this are:

1. The complexity of the mixing process;
2. Complexity of physical analysis of the mechanism of formation of processes and events in the working area of the mixing device;
3. Lack of reliable measurement methods for determining the motion parameters in the process.

This leads to large errors in the design and manufacture of mixing devices used in industry.

As a rule, most of the existing mixers operate in a stationary mode [2], and the working body of the mixer consists of a rotating blade with a constant angular velocity. Rotating the stirrer blades, in turn, acts on the medium being mixed (liquid + solid particles). As a result of this effect, the liquid moves, the intensity of mixing will be higher around the working body of the mixer and decreases as it moves away, but there are sections of the container in which the speed of the liquid is too low or equal to zero, in which the mixing process does not occur. The homogeneity of the prepared mixture is lost, the time for preparing the mixture in the required concentration increases, and a lot of energy is consumed. In addition, after a certain time, the speed of the mixing medium coincides with the speed of the working body, the relative movement between them disappears, as a result of which the liquid moves rhythmically (as in the case of a driver on a long road), separating the particles that make up the mixture, sedimentation is observed. The operating mode used when mixing liquids, which is stationary, has been thoroughly studied by local and foreign scientists. According to scientists, such mechanisms have already used their potential and effectiveness. Today, the above is one of the main problems in the mixing process. If an alternating rotational motion is applied to the working element of the mixer, the mixing process is accelerated, the particles are in turbulent motion, instantly accelerating or decelerating relative to the movement of the liquid.

Simply put, if we somehow transfer variable motion for the mixed fluid, the problems will begin to be solved by themselves. This process can be done in different ways. Recently, devices that create uneven complex movements with variable angular velocities have begun to be used to intensify the mixing process in working bodies and vessels for mixing [2]. To create such a mechanism, the world's first scientists from the Kazan State Agrarian University began to use it in production as a result of research on the Bennett model of the spatial mechanism or devices based on it [3]. However, the designs of the existing mechanisms have a complex structure and are driven by several actuators with ball joints, so their service life is short. In addition, due to the shortcomings of the study of the mixing process, the spatial groups of the created devices have not been studied, and the theory of creating a mixer has not been developed for the lack of a theory of their classification. One of the difficulties of using spatial mechanisms as mixers is the complexity of their modeling and application in production. For example, 250 years ago the Egyptian scientist Philo in his book "Mechanics" theoretically developed a spherical spatial four-hinge mechanism, in which the axes of the rotating hinges intersect at one point. After 1800, the Italian mathematician, philosopher and physician Jorolama Cardano created this mechanism and used it to adjust nautical compasses (if he says, today he used it in the production of a mechanism that was created once). Today, this ball-and-socket mechanism is successfully used as a transmission in all vehicle structures. As another example, a four-hinge spatial mechanism, in which the rotating hinge has only a cylindrical shape, the axes do not intersect or parallel, was theoretically developed in 1903 by the English mathematician Bennett, but he himself did not believe that it would work because he could not create a model. This article has interested many foreign and domestic scientists, since similar five- and six-link spatial mechanisms have been developed from the point of view of geometry, but the models have not been created. Only 75 years later, professors of the Kazan school B.V. Shitikov and P.G. Mudrov managed to create a model and a production model of this spatial mechanism [2, 3]. This suggests that the use of spatial mechanisms in production is much more difficult.

MATERIALS AND METHODS

Our goal is to create a mechanism that acts on the liquid in the horizontal and parallel planes, as well as in the vertical planes, like existing mechanical stirrers. One of the ways to achieve our goal is the mechanism we propose, called the "hinge joint" [4]. The block diagram of the mechanism is shown in Figure 1.a.

The device contains a leading and a driven half-couplings, connected to one another by a pair of crossing telescopic rods located between them, in the form of pistons-cylinders. Each of the coupling halves contains a pivotally connected fork and an earring, and each of the connecting rods is pivotally connected at one end to an earring of one half of the coupling, and at the other end to an earring of the other half of the coupling. Holes are made at the ends of the outer parts of the connecting rods, and blades are attached to the forks.

When the clutch is in operation, the rotation of the driving half-clutch is transferred to the driven half-clutch 2 by means of overlapping telescopic connecting rods with outer 5 and inner 6 parts. Due to the radial arrangement of the shafts, telescopic connecting rods with outer 5 and inner 6 parts work as a piston-cylinder, in one revolution of the shaft they approach and move away from each other as much as possible. At the same time, the blades 11 of the hinge clutch installed in the container 12 with a liquid medium create a rotational movement of the liquid, and the telescopic rods, working as a piston-cylinder, additionally, suck in and pump liquid through hole 10, increasing the intensity of mixing of the liquid medium. The telescopic connecting rod, consisting of 5 outer and 6 inner parts, acts as a piston cylinder and transfers rotary motion from the driving half to the driven half. The leading coupling half has a radial displacement (kurtosis) of length ε relative to the driven coupling half. The fork 3 and the shackle 4 are connected to each other by means of hinges 9, the axes of which are located perpendicular to the axis of rotation of the fork 3. The outer 5 and inner 6 parts of the telescopic rods are connected by the corresponding shackles 4 by means of cylindrical hinges 7 and 8, the axes of which are parallel to each other and perpendicular to both the axis of the fork 3 and the axis of the hinges 9. The outer parts of the telescopic rods 5 have openings 10 close to the respective pivot joints. The articulated coupling is installed in a container 12 with a liquid medium.

When the clutch is in operation, the rotation of the driving half-clutch is transferred to the driven half-clutch 2 by means of overlapping telescopic connecting rods with outer 5 and inner 6 parts. Due to the radial arrangement of the shafts, telescopic connecting rods with outer 5 and inner 6 parts work as a piston-cylinder, in one revolution of the shaft they approach and move away from each other as much as possible. At the same time, the blades 11 of the hinge clutch installed in a container 12 with a liquid medium create a rotational motion of the liquid, and the telescopic connecting rods, working as a piston-cylinder, additionally suck in and pump liquid through the hole 10. As a result, the liquid is mixed both horizontally and vertically. This leads to the fact that

the liquid is stirred without sediment and a mixture of the same concentration is formed. This mechanism, unlike other mechanisms, has three outlet links that move the fluid, the first of which is a driven coupling half, and the second and third are an internal connection capable of sucking and blowing out fluid - two telescopic connecting rod and its path.

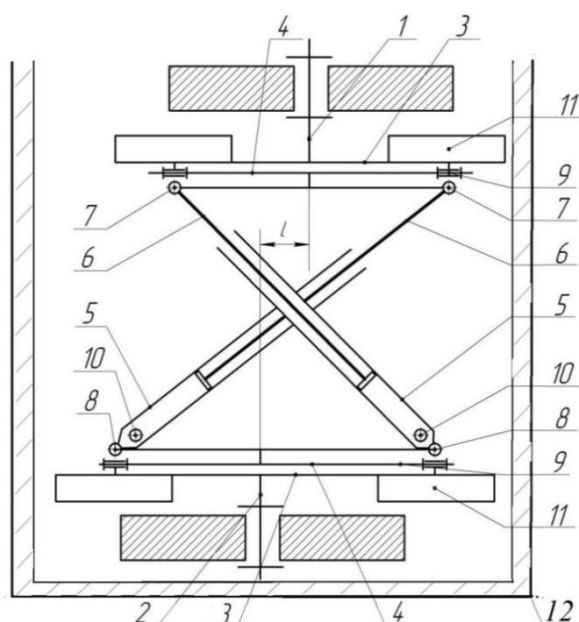

a)

b)

Fig. 1. Block diagram (a) and model (b) of the articulated coupling.

1, 2 - leading and driven half-couplings; 3-plug; 4-earrings; 5, 6-outer and inner (cylinder and piston) parts of the telescopic connecting rod, 7, 8-cylindrical hinges, 9-axis of the hinges, 10-holes drilled in the cylinder, 11- agitator blades, 12- cylindrical vessel filled with liquid for mixing

Analysis of scientific and educational literature on machines and mechanisms showed that many literature and monographs are devoted to single-engine mechanisms, which are external to the input connection, and the generalized force that drives it. Modern mechanical engineering is focused on creating a multifunctional machine that provides high reliability, accuracy and productivity. In mechanisms where the incoming steam is internal, the generated force is applied to its movable joint and, naturally, significantly increases the parameters required for the machine. These mechanisms are now used in lifting and transporting, earthmoving, drilling, piling, road and construction machines, as well as in industrial robots and medicine [5].

The proposed mechanism, called the articulated clutch [4], is spatial; its model was created to study their kinematics and performance (Fig. 1.b).

When studying the structure [6] and kinematics [7] of spatial

mechanisms, it was shown that the found equation for the angular velocity and angular acceleration of the connecting rod is universal and applicable to a connecting rod with different structural parameters of the primary mechanism. Visual studies, strength, mobility, performance and kinematics of a newly created mechanism are often studied in a mechanism model [8, 9, 10]. Kinematic analysis of the mechanism, i.e. determining the laws of motion of its input and output coupling halves, as well as telescopic connecting rods, is part of a set of parameters indicating what it is capable of. There are many ways to determine these parameters, the most common of which are graphical, graphic-analytical, analytical and experimental methods. The first three methods use the kinematic scheme of the mechanism. We use an experimental research method. From a methodological point of view, an experiment ensures the transition of research from slow activity to active one. Experiments can be natural or artificial. Natural experiments are carried out to study social phenomena in production, in life, etc. Artificial experiments are widely used in engineering and other sciences. Depending on the nature of the investigated object or model of the process, the choice and conduct of experiments, they are divided into laboratory and production. Laboratory experiments are carried out on special model devices and stands using standard instruments and appropriate equipment. In an experiment, you can change the conditions for studying an object, perform it in its pure form, return it, study it on simplified, reduced models.

The speed of the motor connected to the input clutch is variable and can vary from 6 to 50 rpm. In the experiment, the number of revolutions of the input link was measured with a non-contact tachometer AR926. To do this, a small piece of opaque adhesive tape was cut out and glued to the rotating surface as a mark. The mark used in the measurement is of course guaranteed, because it came into the field of view of the sensor once in one revolution of the object. During the measurement, the applied mark must necessarily fall into the field of view of the sensor once in one revolution of the object. The half-couplings, which are the input and output links, rotate in the horizontal plane. To study their laws of motion, measurements were carried out in three links of the mechanism at different values of the rotation of the input link with approximately a 10° step. Before starting the measurement work, we identified the first and second telescopic cranks. We chose the first telescopic connecting rod farthest from the axis of rotation, and the second - the closest to this axis. We took the position of the input link, corresponding to this position of the first telescopic rod, as the starting point of movement, and took measurements from this point. Likewise, we will denote the path of the first telescopic rod as S_{ik} ($k = 1$) and the path of the second as S_{ik} ($k = 2$). The

measurements were carried out with three repetitions. To measure the angular coordinates of the input and output links, angular scales (protractors) are placed on the coupling axes, which can vary within the following limits: $0^\circ \leq \varphi \leq 360^\circ$ with an accuracy of 1° [18]. The results were recorded in the experimental data log. Knowing the time required for a complete revolution of the input half-coupling, we calculated the angle of rotation of the hinges, connecting them with time. The experiment was carried out at four values of excess, i.e. the radial displacement between the axes of the driving and driven half-coupling was $\varepsilon = 5$; twenty; 35 and 50 mm. In [17], the laws of motion of the input and output clutch are given, determined experimentally for the eccentricity value $\varepsilon = 20$ mm at the number of revolutions of the input link $n = 22$ rpm. This article presents the results of a study of the motion of the input and output coupling halves, as well as the second and third output links for four values of the number of revolutions of the input link at a constant value ($e = 20$ mm) of kurtosis.

The graphical presentation of the results of the experiment, the definition of its mathematical expression allows you to better understand the physical nature of the process under study. This requires mathematical calculations. Today, modern computer mathematics, computer technologies have become an integral part of all industries and professions, that is, they have provided a whole package of integrated software systems for automating mathematical calculations [12, 13, 14]. The system of mathematical calculations is a simple, well-developed and verified system within the framework of these systems. It included the experience, rules, and methods of mathematical calculations accumulated as a result of the development of mathematics over the years. Therefore, we used the Mathcad package to graphically represent the results of experiments and to determine the algebraic expression of the functional dependence of the position of the input and output links of the mechanism on time.

The Mathcad package is a software tool for performing engineering calculations that allows you to solve algebraic and differential equations with variable and invariant parameters, analyze functions, look for their extrema, build tables and graphs to analyze the solutions found. Simultaneously with the appearance of a discrete variable in Mathcad, it became possible to find the values of functions for the values of a variable and to build tables and graphs based on the results obtained without using programming operators. Discrete variables are loop statements. Such variables can have sequential numbers that increase or decrease with a certain step. Experimental results (arrays) consist of one or more discrete variables and their functions. Mathcad has a Matrix panel used to create arrays. An array template is selected by entering the

number of columns and rows in its dialog box. Each empty cell is filled with discrete values of the experimental results. Then we get the matrix form as a row. Now, to display them graphically, press the x-y Plot button on the Graph panel, place the time name t_i on the abscissa axis and the names φ_{ij} of the rotation angle of the input and output links along the ordinate axis of the resulting two-dimensional graphic template. Figure 2 shows a graph of the patterns of motion of the input half-coupling for different values of the number of revolutions of the input link along the dimensional (a) and dimensionless (b) coordinate axes. On the graph, φ_{ij} is the angle of rotation of the links, measured in $^\circ$, which varies depending on the number of revolutions i and j with which the link ($j = 1$ input, $j = 2$ outputs). In this case, the dependence $\varphi_{ij} = f(t_i)$ is given for four values of i (6; 14; 22 and 30 rpm) revolutions at $j = 1$. As can be seen from the graph, for each number of revolutions of the input link, the input half-coupling moves according to a rectilinear law (Fig. 2, a), which differs from each other by the slope. Experiments show that the slope of the straightness increases in proportion to the number of revolutions of the input link. Let us introduce a dimensionless angle of rotation $\varphi_{ij} = \varphi_{ij} / \varphi^*$ and time $t_{ij} = t_i / t^*$ for the input ($j = 1$) and output ($j = 2$) half couplings. Here the maximum angle of rotation is equal for the full period and the time taken for this rotation. As a result, we find that the experimental data will be around one line (Fig. 2, b).

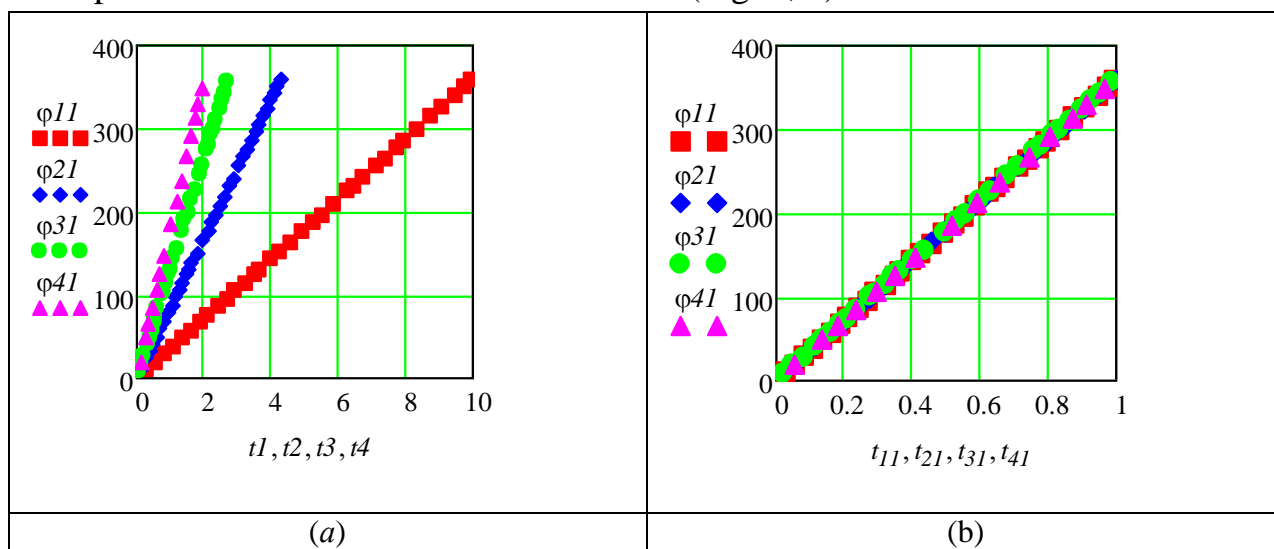

Fig. 2. Dimensional (a) and dimensionless (b) change in time of the law of motion of the input half-coupling for different values of the number of revolutions of the input link. Symbols \blacksquare ; \blacklozenge ; \bullet and \blacktriangle corresponds to the number of rotation of the input link, respectively equal to 6; fourteen; 22 and 30 rpm values.

Figure 3 shows the time variation of the angle of rotation of the output ($j = 2$) half-coupling over a period of time. As can be



seen from the figure, the law of motion of the output half-coupling for different values of the number of revolutions of the input link slightly deviates from the law of a straight line (Fig. 3. a). This means that the angular velocity of the output coupling half is variable. The law of motion of the output half-coupling in dimensionless coordinates is shown in Figure 3. b.

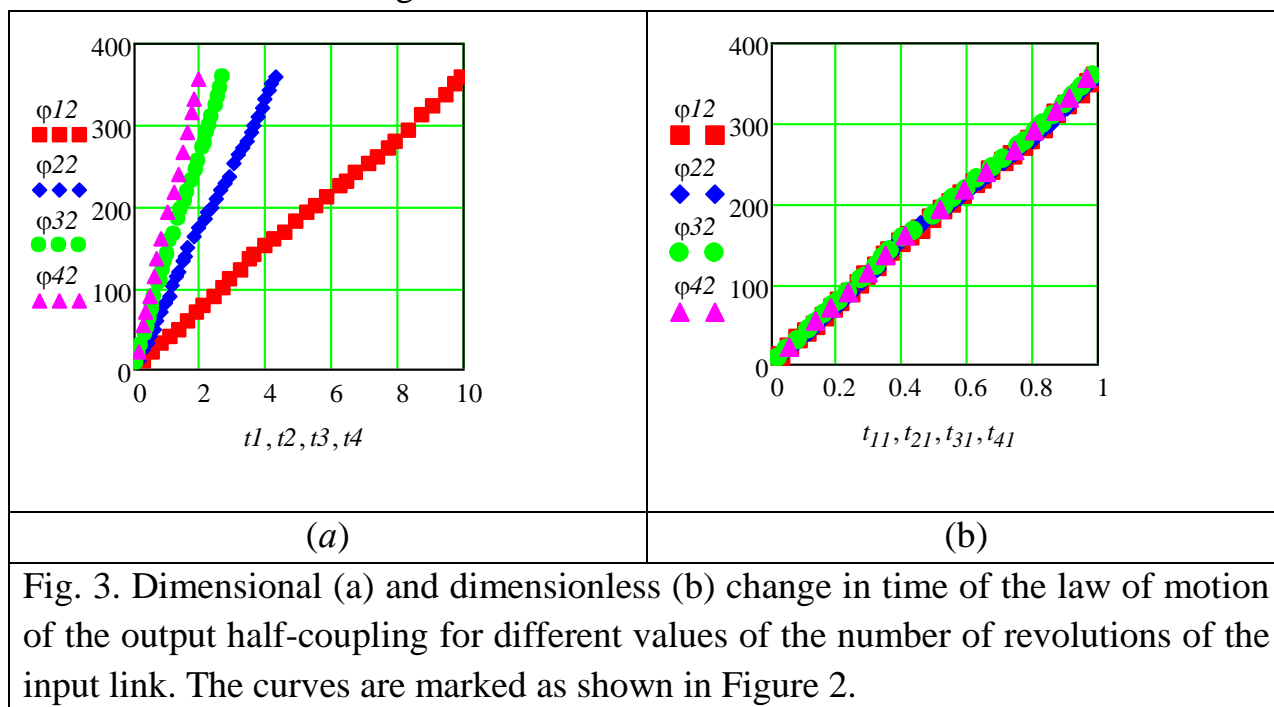

Fig. 3. Dimensional (a) and dimensionless (b) change in time of the law of motion of the output half-coupling for different values of the number of revolutions of the input link. The curves are marked as shown in Figure 2.

Now let us define an approximate mathematical expression for the law of motion of the input ($j = 1$) and output ($j = 2$) half-couplings, that is, a function representing the experimental results in order to determine the regularity with which the angular velocity of the output half-coupling changes. Mathcad has interpolation functions that differ in the way the points obtained from the experiment are connected (straight line or different curves). The most common of these is the so-called cubic spline interpolation, which combines all points obtained experimentally with segments of cubic polynomials. As a result of interpolation, you can obtain a function or dataset with any number of interpolation points. If the result is in the form of a function, it can be integrated, differentiated, and used as a function in subsequent calculations. Mathcad [12, 13] has created a built-in function `interp` for cubic spline interpolation of experimental data. The function `interp(vs, tij, φij, t)` is used to interpolate the experimental results presented in Figures 2 and 3. In this case `vspline(tij, φij)`, `pspline(tij, φij)` or `cspline(tij, φij)` are vectors of second-order derivatives of the generated functions that form a vector of curve coefficients approaching a straight, square or cubic parabola at the

boundary point, respectively. In this expression t_{ij} - a vector of experimental values of the argument (time in a period) located in the growth sequence; φ_{ij} - vector of experimental values of the function (angle of rotation of the input and output coupling halves); t is the vector value of the argument at which the function is calculated that interpolates the experimental results. Interpolation of a matrix consisting of experimental data described in the plotting requires the calculation of the interpolation function for all its values. To perform computational operations on a matrix, we transpose the elements of the matrix as $(t_{ij})^T \rightarrow$ and $\varphi_{ij}^T \rightarrow$ using a key $M^T \rightarrow$ on the symbolic computational operator. We used the function

$$\varphi_{ij.csp}(t_i) := \text{interp}(\text{cspline}(t_{ij}, \varphi_{ij}), t_{ij}, \varphi_{ij}, t_i) \quad (1)$$

$\varphi_{ij} = f(t_{ij})$ to interpolate the graph. This cubic spline interpolation function was calculated and plotted over the interval $t_i = 0, 0.05 \dots \max(t_{ij})$ for different values of i and j ($i = 1; 2; 3; 4$ and $j = 1; 2$) (Figure 4). As can be seen from the figure, the calculated spline function (1) fully describes the data obtained as a result of the experiment. Therefore, this function represents the law of motion of the input and output coupling halves of a mechanism called the articulated clutch.

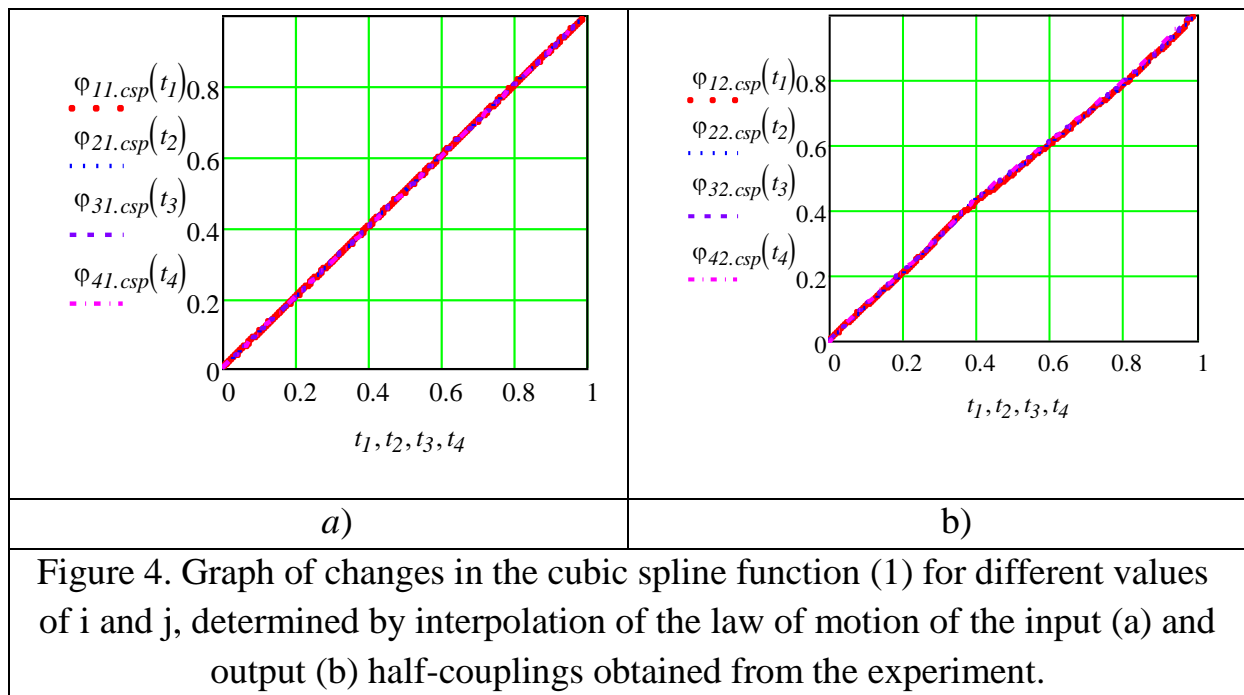

Figure 4. Graph of changes in the cubic spline function (1) for different values of i and j , determined by interpolation of the law of motion of the input (a) and output (b) half-couplings obtained from the experiment.

We know that if the law of motion of a link is known, then all the kinematic parameters of this link can be found. The angular velocities of the input and output coupling halves can be determined through the expression

$$\omega_{ij}(t_i) = \frac{d}{dt_i} \varphi_{ij.csp}(t_i) \quad (2)$$

taking into account their law of motion (1). According to formulas (2), for different values of the number of revolutions of the input link i , the change in the angular velocities of the input ($j = 1$) and output ($j = 2$) half couplings was determined for the period and is shown in Figure 5.

Experiments (Fig. 5) show that the angular velocity of the input half-coupling remained unchanged for a certain period of time, and this established regularity also remained for different values of the number of revolutions of the input link $\omega_{i1} = const$. The angular velocity of the output half-coupling changed several times during the same period, and this $\omega_{i2} = var$ law was retained at different values of the number of revolutions of the input link. The change in the angular speed of the output half-coupling for one revolution of the input link is usually expressed by the coefficient of uneven movement or the degree of unevenness. The degree of motion irregularity is determined by the expression $\delta = (\omega_{max} - \omega_{min}) / \omega_{cp}$. Calculations show that δ changes over the period. This change confirms that the inertial force defined by the formula $F_{max} = m \cdot r \cdot \omega_{max}^2$; $F_{min} = m \cdot r \cdot \omega_{min}^2$ is also variable. The resulting inertial force of inertia acts on the liquid with additional force, increasing the intensity of its mixing and preventing the formation of sludge. It also maintains a constant turbulent flow of the agitated fluid.

In theory, when a fluid is mixed using a swivel clutch, its output half clutch rotates at different angular velocities within the cycle, accelerating or decelerating relative to the fluid and acting on it. With an increase in the angular velocity of the working medium, it acts on the liquid, and when it decreases, the liquid gains on the working body. Under the influence of the working fluid during such a movement, the layers of liquid create a different area of action in different directions, and this effect is transmitted to the adjacent layers. As a result, there is always an inertial force of different magnitude and direction between the mixing liquid and the working medium of the mixer. This creates conditions for the stabilization of one or another technological (normal distribution of suspended particles over the volume of liquid or their absence of sedimentation, uniformity of temperature in the mixing zone, acceleration of heat and mass transfer) process.

From the above, it can be seen that the mixing process occurs in a non-stationary mode in a turbulent state. As a result, the time required for the concentration of the mixed liquid to be uniform throughout the volume of the vessel is reduced and less energy is consumed. If the process took place in a stationary mode, the movement of the liquid would occur in a laminar state.

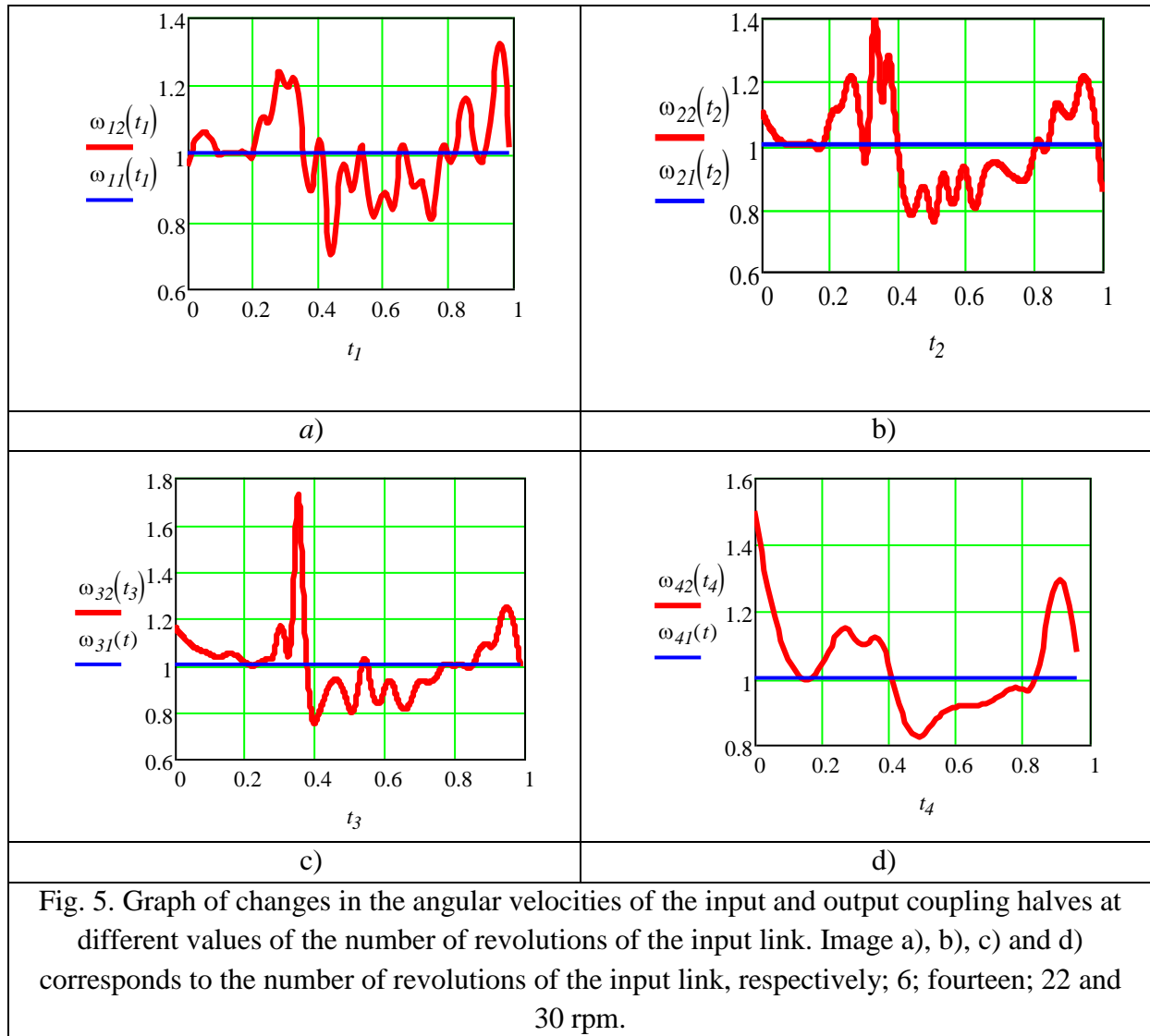

To imagine that the angular velocity of the output coupling half, which is the first working element of the mechanism, changes sharply over a period, it is enough to look at the movement of two telescopic connecting rods. The latter have two functions. Participation for the transfer of rotary motion from the input half of the mechanism to the output half of the coupling is the first function. Second, it works as a piston pump that mixes liquids, sucking and pumping them. This means that these connecting rods are the second and third working bodies of the mechanism, and also participate in the transfer of motion from the input half-coupling to the first working body. Telescopic connecting rods belong to the category of rocker mechanisms in which a moving part, like a stone (piston), participates in reciprocating motion along a movable guide. In addition, the connecting rod makes a rotational movement depending on the kurtosis length around the axis connected to the output coupling half.

Now let's study the law of motion of telescopic rods, which are the second and third working bodies. There are two telescopic rods, the difference between them is that one of them works simultaneously to suck in liquid and the other to pump liquid. When the input link begins to move, the first telescopic connecting rod begins to suck in, and the second begins to pump fluid. When we studied the movement of the output coupling half, when the input link was rotated through a certain angle, the movement paths of the corresponding hydraulic pistons were also measured. The results were recorded in an experimental notebook, noting S_{ik} . In this case, $k=1$ it indicates that the first connecting $k=2$ rod belongs to the second connecting rod, and i , as we said at the beginning of the article, determines the number of revolutions of the input link. Figure 6 shows the law of motion of two telescopic rods, operating as a piston pump, used to drive the output half-coupling, as well as by suction-pumping stirring liquids at different values of the number of revolutions of the input link.

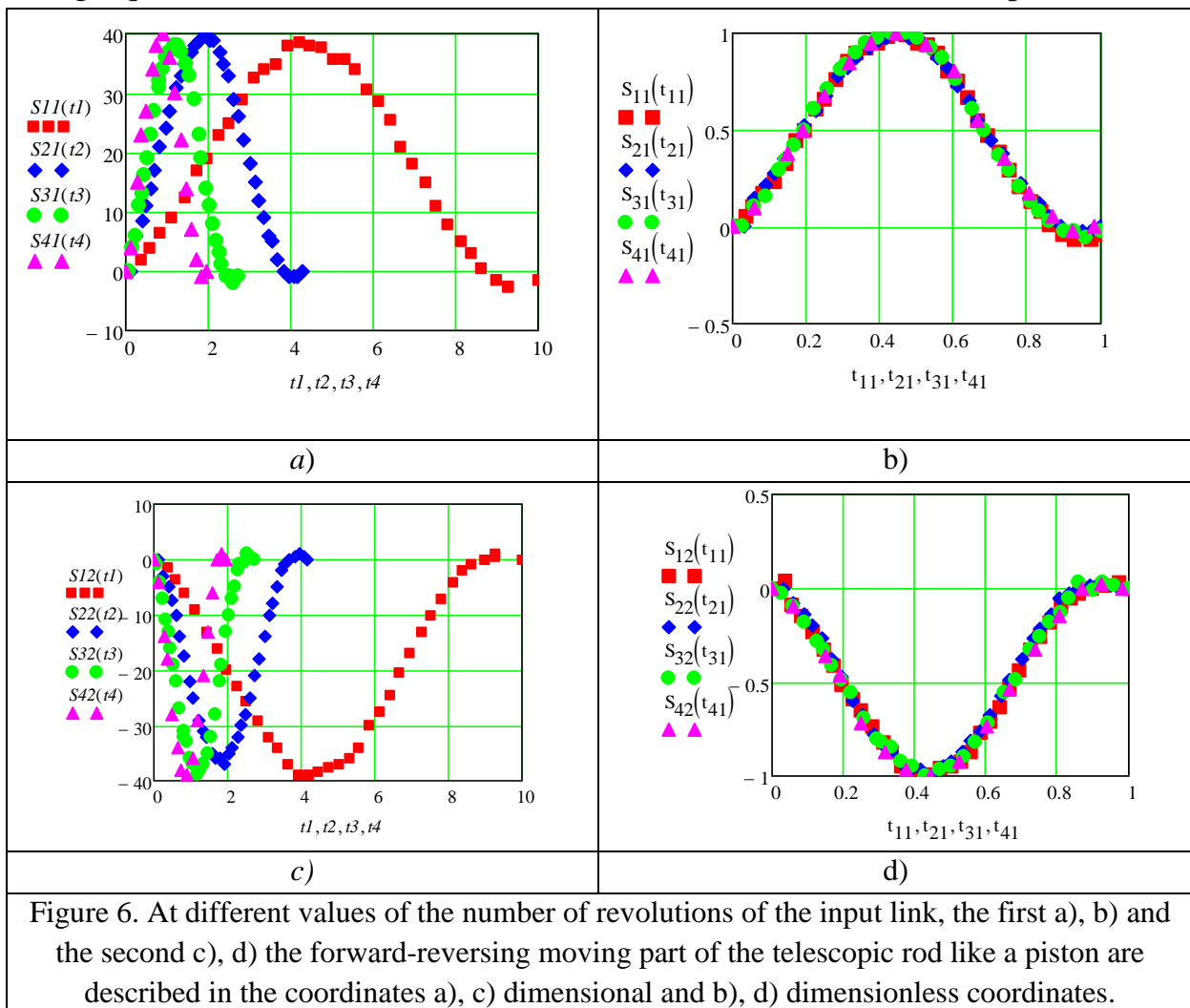

Figure 6. At different values of the number of revolutions of the input link, the first a), b) and the second c), d) the forward-reversing moving part of the telescopic rod like a piston are described in the coordinates a), c) dimensional and b), d) dimensionless coordinates.

As the number of revolutions of the input link increases, the time $t^* = 60/ni$ required for it to complete one revolution decreases. This shows that the law of motion is compressed along the abscissa (Fig. 6). But since the kurtosis is constant, the path of the moving part (piston) of the telescopic connecting rod is also constant for four values of the number of revolutions of the input link. She makes $S_{ik_{max}} \approx 40_{MM}$. If we introduce dimensionless coordinates $S_{ik} = S_{ik} / S_{ik_{max}}$ and $t_{ik} = ti / t^*$ in the graph $S_{ik} = f(ti)$ - the law of motion of the pistons (Figures a, c) of the telescopic connecting rod, shown in Fig. 6, then all the experimental data are placed around a single curve (Fig. 6 b, d). As you know, the pistons of the telescopic connecting rods change direction in their two extreme positions and at the same time stop instantly (a condition called the dead position). After this position, the speed of movement of the piston increases from zero to the maximum value and again decreases to an instantaneous stop. Thus, it performs the acceleration and deceleration process during one input period. Such an uneven movement of the connecting rod provides a variable angular velocity of the output coupling half attached to it.

RESULTS AND DISCUSSION

1. On the basis of the structural diagram of the "Articulated clutch" mechanism designed for mixing liquids, its model was developed and its ability to move was confirmed. This mechanism, unlike other mechanisms used for this purpose, has one input and three output links.

2. At different values of the number of revolutions of the input link, it was experimentally established that the input half-coupling rotates according to a rectilinear law and its angular velocity does not change during one cycle.

3. At different values of the number of revolutions of the input link, it has been experimentally established that the driven coupling half, which is its first output link, moves according to a curvilinear law. With the help of the Mathsad program, the cubic interpolation function of this law was determined. The change in its angular velocity several times over a period is shown by a first-order numerical differential obtained from the law of motion.

4. This means that the angular velocity of the output coupling half will both increase and decrease in one rotation cycle. With an increase in the speed of the output coupling half, they act on the liquid, and with a decrease in the speed, the fluid being mixed acts on the working body and the adjacent flow layers and creates its own field of action, and this field is variable in different directions.

5. The law of uneven motion of telescopic connecting rods was experimentally determined, one of them working for suction, and the second for discharge, like a piston pump. Since this movement of it is transmitted to the driven clutch, it was shown that the clutch must be in rotational motion with a variable angular velocity of rotation during one cycle.

REFERENCES

1. Barabash V.M., Abiev R.Sh., Kulov N.N. Review of works on the theory and practice of mixing // Theoretical foundations of chemical technology. 2018.Vol. 52. No. 4. P. 367-383.
2. Mudrov A.G. Designs and model of mixing in apparatuses with a stirrer // Izvestiya KGASU. 2018. No. 1 (43). S. 226-233.
3. Mudrov A.G., Mardanov R.Sh. Review of research on spatial mechanisms with rotary hinges // Theory of mechanisms and machines. 2015. Volume 13. No. 2 (26). S. 62-75.
4. Semenov Yu.A. Application of machines and mechanisms with internal inputs // Theory of mechanisms and machines. 2003. No. 1. S. 30-49.
5. Yarullin M.G., Mingazov M.R. Structural synthesis of a two-movable spatial 5R mechanism and elements of tracking control // Bulletin of the Samara Scientific Center of the Russian Academy of Sciences. 2014.Vol. 16.No. 6.P. 214-220.
6. Evgrafov A.N., Petrov G.N. Geometry and kinematics of the turbulent mixer mechanism // Modern mechanical engineering. Science and education. 2013.S. 701-708.
7. Yarullin M.G., Mingazov M.R. Kinematics of characteristic points of the working links of the spatial 4R-mechanism as an activator of mixing processes // Bulletin of ISTU. 2014. No. 3 (63). S. 34-38.
8. Mudrov A.G. Investigation of spatial mechanisms with a special structure // Bulletin of Kazan State Agrarian University. 2019. No. 2 (53). S. 111-116.
9. Semenov Yu.A., Semenova M.S. Features of the kinematic analysis of mechanisms with internal inputs // Theory of mechanisms and machines. 2004. Volume 2. No. 2. S. 30-39.
10. Ryazantsev D.A. Development of a system for measuring angular displacements // Measurement. Monitoring. Control. Control. - 2018. - No. 4 (26). - S. 5-9. - DOI 10.21685 / 2307-5538-2018-4-1.
11. Makarov E. Engineering calculations in Mathcad 15: Training course. - SPb .: Peter. 2011 .-- 400 p.

12. Matsyuk I.N., Tretyakov V.M., Shlyakhov E.M. Analytical kinematics of flat lever mechanisms of high classes using Mathcad // Theory of mechanisms and machines. 2012. Volume 10. No. 1. P. 65-70.
13. Ioffe M.L. On the choice of the parameters of the Bennett mechanism and its modeling in MATLAB // Bulletin of higher educational institutions. Mechanical engineering. 2016. No. 2 (671). S. 11-19.
14. Toshov B.R., Khamroev Sh.G. Stirring of liquids with a changing diameter of a mechanical stirrer // Collection of scientific works of BNTU. Minsk. 2019. Vol. 2. S. 197-203.
15. Toshov B.R., Khamzaev A.A., Khamroev Sh.G. Kinematics of the hinge coupling used in a mechanical mixer // Young Scientist. 2017. No. 1 (135). S. 89-95.
16. Toshov B. R., Hamroyev S. G. Suyuqliklarni aralashtirishda ishlatiladigan sharnirli mufta zvenolarining harakat qonunini aniqlash // Young Scientist 2020. No. 38 (328). S. 219 - 226.

